



Characteristics



- Specially designed for insects control at entranceways such as food establishments and industry, hospitals or clean zones.
 - High velocity air barrier to prevent flying insects from entering a building. Up to 3m height doors according to NSF 37 standard
 - Self-supporting casing construction made of galvanized steel plate, finished in structural epoxy-polyester painting white colour RAL9016 as standard. Other colours or stainless steel are available on request.
 - Large perforated inlet grille avoiding intensive maintenance.
 - Anodized aluminium outlet vanes, airfoil shaped, adjustable from 0 to 15° each side.
 - Double-inlet centrifugal fans driven by an external rotor motor and low noise level. 5-speed selector.
 - "A" type without heating, air only.
 - Includes Plug&Play Hand Auto control with 10m RJ45 cable and magnetical door contact.
- Optional: Clever control (programmable, automatic, intelligent, energy saving, Modbus RTU for BMS...).

Specifications

AIR ONLY

Model	Airflow m ³ /h	Fans Power 230V-50Hz kW	Fans Current 230V-50Hz A	Noise Level (5 m) dB(A)	Weight kg
FLY KL 1000 A	4000	1,04	4,40	63	76
FLY KL 1500 A	6000	1,56	6,60	64	114
FLY KL 2000 A	8000	2,08	8,80	65	153
FLY KL 2500 A	10000	2,60	11,00	66	187
FLY KL 3000 A	12000	3,12	13,20	67	225

Dimensions

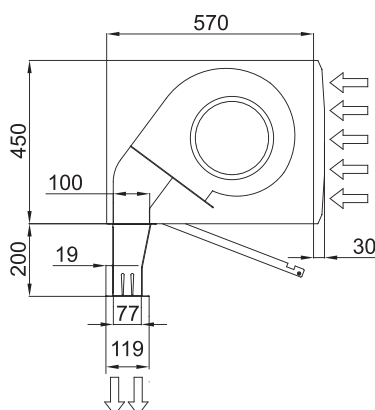
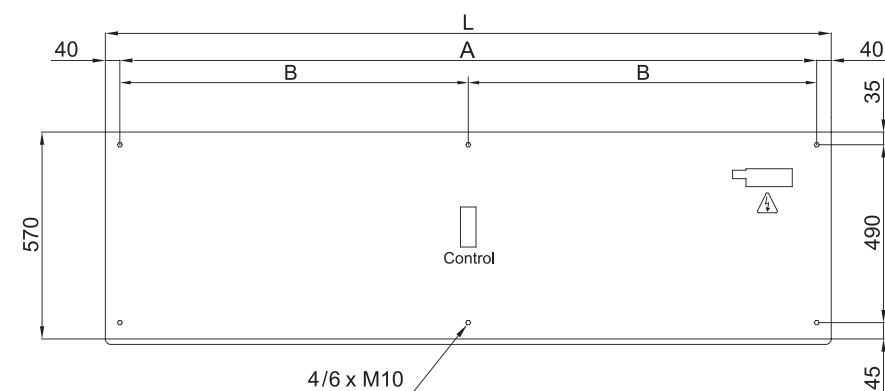

L	A	B
1000	920	-
1500	1420	710
2000	1920	960
2500	2420	1210
3000	2920	1460

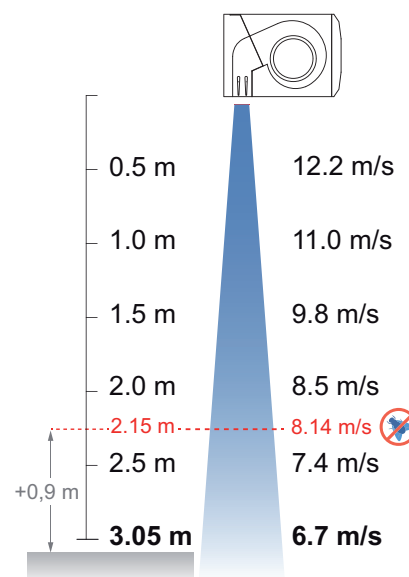

According to standard NSF-37-2012, the maximum installation height is the speed profile point at 8,14m/s plus 0,9m. So FLY KL can be used until 2,15m+0,9m=3,05m.