



Characteristics

Recessed Dam air curtain with Kleenfan photocatalysis technology that disinfects and purifies the air, for commercial and industrial doors



- Kleenfan technology with photocatalytic purificant action fans. UV-A rays, from the long-life led, act on the titanium dioxide of the turbine generation Reactive Oxygen Species (ROS) than, through oxidation /reduction reactions, inactivate wide range of pathogenic microorganisms (viruses and bacteria). It mineralizes most of the pollutants present in urban areas produced by vehicles and industry (NOx, SOx, COx, formaldehydes, VOCs, etc.).
- Compact and low profile recessed air curtain with full grille view.
- Self-supporting casing construction made of galvanized steel plate, ready to be installed recessed in a false ceiling.
- Inlet grille (free of maintenance) made with aluminium profiles and blow-out nozzle, integrated in a single white frame colour RAL 9016. Other colours are available on request.
- EC Double-inlet centrifugal fans driven by an external rotor motor and low noise level, with very low consumption efficiency fans.
- “P” type with water heated coil. “E” type with electrical shielded elements, three stages with integrated regulation. “A” type without heating, air only. Optional expansion DX coil.
- Includes Plug&Play control with 7m RJ45 cable and infrared remote control. Optional: Clever control (programmable, automatic, intelligent, energy saving, Modbus RTU for BMS...)

Specifications

50Hz

Unheated		
Model	Nominal Airflow (m³/h)	Recommended Installation Height (m)
RDAM ECM 1000 A FC	1840	2,5-3,8
RDAM ECM 1500 A FC	2760	2,5-3,8
RDAM ECM 2000 A FC	3680	2,5-3,8
RDAM ECM 2500 A FC	4600	2,5-3,8
RDAM ECG 1000 A FC	2700	3-4,2
RDAM ECG 1500 A FC	3600	3-4,2
RDAM ECG 2000 A FC	5400	3-4,2
RDAM ECG 2500 A FC	6300	3-4,2

Electrical Heating			
Model	Nominal Airflow (m³/h)	Electrical Heating Capacity 400Vx3 (kW)	Recommended Installation Height (m)
RDAM ECM 1000 E FC	1840	3/6/9	2,5-3,8
RDAM ECM 1500 E FC	2760	4/8/12	2,5-3,8
RDAM ECM 2000 E FC	3680	6/12/18	2,5-3,8
RDAM ECM 2500 E FC	4600	6/12/18	2,5-3,8
RDAM ECG 1000 E FC	2700	5/10/15	3-4,2
RDAM ECG 1500 E FC	3600	7,5/15/22,5	3-4,2
RDAM ECG 2000 E FC	5400	10/20/30	3-4,2
RDAM ECG 2500 E FC	6300	10/20/30	3-4,2

Water Heating					
Model	Nominal Airflow (m³/h)	Heating Capacity 80/60°C (kW)	Heating Capacity 60/40°C (kW)	Heating Capacity 50/40°C (kW)	Recommended Installation Height (m)
RDAM ECM 1000 P86 FC	1720	9.38	-	-	2,5-3,8



Water Heating					
Model	Nominal Airflow (m³/h)	Heating Capacity 80/60°C (kW)	Heating Capacity 60/40°C (kW)	Heating Capacity 50/40°C (kW)	Recommended Installation Height (m)
RDAM ECM 1500 P86 FC	2580	14.58	-	-	2,5-3,8
RDAM ECM 2000 P86 FC	3440	21.12	-	-	2,5-3,8
RDAM ECM 2500 P86 FC	4300	27.53	-	-	2,5-3,8
RDAM ECG 1000 P86 FC	2550	11.89	-	-	3-4,2
RDAM ECG 1500 P86 FC	3400	17.29	-	-	3-4,2
RDAM ECG 2000 P86 FC	5100	26.86	-	-	3-4,2
RDAM ECG 2500 P86 FC	5950	33.63	-	-	3-4,2
RDAM ECM 1000 P64 FC	1720	-	8.77	-	2,5-3,8
RDAM ECM 1500 P64 FC	2580	-	14.02	-	2,5-3,8
RDAM ECM 2000 P64 FC	3440	-	18.7	-	2,5-3,8
RDAM ECM 2500 P64 FC	4300	-	23.33	-	2,5-3,8
RDAM ECG 1000 P64 FC	2550	-	11.27	-	3-4,2
RDAM ECG 1500 P64 FC	3400	-	16.77	-	3-4,2
RDAM ECG 2000 P64 FC	5100	-	24.14	-	3-4,2
RDAM ECG 2500 P64 FC	5950	-	28.84	-	3-4,2
RDAM ECM 1000 P54 FC	1720	-	-	8.74	2,5-3,8
RDAM ECM 1500 P54 FC	2580	-	-	14.71	2,5-3,8
RDAM ECM 2000 P54 FC	3440	-	-	19.13	2,5-3,8
RDAM ECM 2500 P54 FC	4300	-	-	24.95	2,5-3,8
RDAM ECG 1000 P54 FC	2550	-	-	11.5	3-4,2
RDAM ECG 1500 P54 FC	3400	-	-	17.86	3-4,2
RDAM ECG 2000 P54 FC	5100	-	-	25.24	3-4,2
RDAM ECG 2500 P54 FC	5950	-	-	31.38	3-4,2

60Hz

Unheated		
Model	Nominal Airflow (m³/h)	Recommended Installation Height (m)
RDAM ECM 1000 A FC	1840	2,5-3,8
RDAM ECM 1500 A FC	2760	2,5-3,8
RDAM ECM 2000 A FC	3680	2,5-3,8
RDAM ECM 2500 A FC	4600	2,5-3,8
RDAM ECG 1000 A FC	2700	3-4,2
RDAM ECG 1500 A FC	3600	3-4,2
RDAM ECG 2000 A FC	5400	3-4,2
RDAM ECG 2500 A FC	6300	3-4,2

Electrical Heating			
Model	Nominal Airflow (m³/h)	Electrical Heating Capacity 400Vx3 (kW)	Recommended Installation Height (m)
RDAM ECM 1000 E FC	1840	3/6/9	2,5-3,8
RDAM ECM 1500 E FC	2760	4/8/12	2,5-3,8
RDAM ECM 2000 E FC	3680	6/12/18	2,5-3,8
RDAM ECM 2500 E FC	4600	6/12/18	2,5-3,8
RDAM ECG 1000 E FC	2700	5/10/15	3-4,2
RDAM ECG 1500 E FC	3600	7,5/15/22,5	3-4,2
RDAM ECG 2000 E FC	5400	10/20/30	3-4,2
RDAM ECG 2500 E FC	6300	10/20/30	3-4,2



Water Heating					
Model	Nominal Airflow (m ³ /h)	Heating Capacity 80/60°C (kW)	Heating Capacity 60/40°C (kW)	Heating Capacity 50/40°C (kW)	Recommended Installation Height (m)
RDAM ECM 1000 P86 FC	1720	9.38	-	-	2,5-3,8
RDAM ECM 1500 P86 FC	2580	14.58	-	-	2,5-3,8
RDAM ECM 2000 P86 FC	3440	21.12	-	-	2,5-3,8
RDAM ECM 2500 P86 FC	4300	27.53	-	-	2,5-3,8
RDAM ECG 1000 P86 FC	2550	11.89	-	-	3-4,2
RDAM ECG 1500 P86 FC	3400	17.29	-	-	3-4,2
RDAM ECG 2000 P86 FC	5100	26.86	-	-	3-4,2
RDAM ECG 2500 P86 FC	5950	33.63	-	-	3-4,2
RDAM ECM 1000 P64 FC	1720	-	8.77	-	2,5-3,8
RDAM ECM 1500 P64 FC	2580	-	14.02	-	2,5-3,8
RDAM ECM 2000 P64 FC	3440	-	18.7	-	2,5-3,8
RDAM ECM 2500 P64 FC	4300	-	23.33	-	2,5-3,8
RDAM ECG 1000 P64 FC	2550	-	11.27	-	3-4,2
RDAM ECG 1500 P64 FC	3400	-	16.77	-	3-4,2
RDAM ECG 2000 P64 FC	5100	-	24.14	-	3-4,2
RDAM ECG 2500 P64 FC	5950	-	28.84	-	3-4,2
RDAM ECM 1000 P54 FC	1720	-	-	8.74	2,5-3,8
RDAM ECM 1500 P54 FC	2580	-	-	14.71	2,5-3,8
RDAM ECM 2000 P54 FC	3440	-	-	19.13	2,5-3,8
RDAM ECM 2500 P54 FC	4300	-	-	24.95	2,5-3,8
RDAM ECG 1000 P54 FC	2550	-	-	11.5	3-4,2
RDAM ECG 1500 P54 FC	3400	-	-	17.86	3-4,2
RDAM ECG 2000 P54 FC	5100	-	-	25.24	3-4,2
RDAM ECG 2500 P54 FC	5950	-	-	31.38	3-4,2



Dimensions

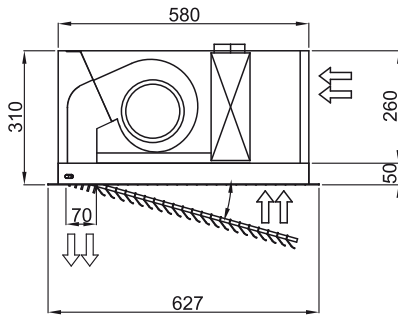
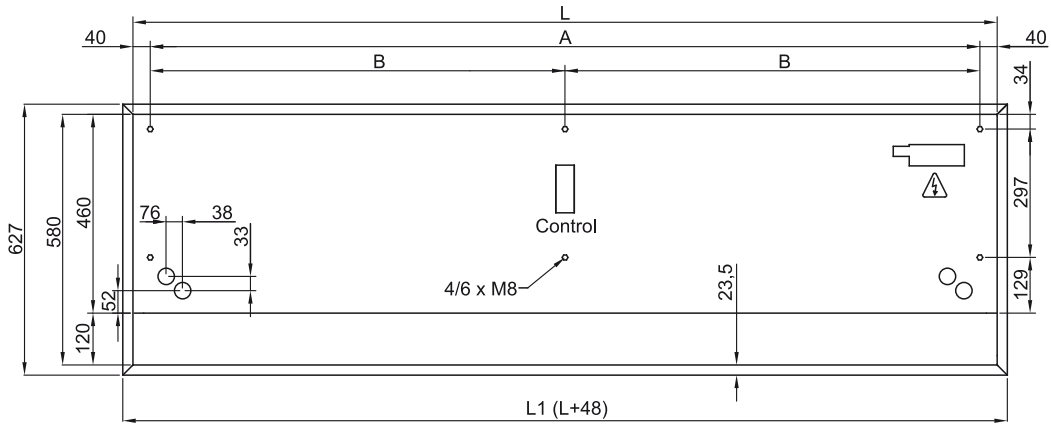

	L	L1	A	B
Recessed Dam 1000	1000	1048	920	-
Recessed Dam 1500	1500	1548	1420	710
Recessed Dam 2000	2000	2048	1920	960
Recessed Dam 2500	2500	2548	2420	1210